



MIKE

PENDANT CONTROL STATION

Mike is a pendant control station used for the control of industrial machines. This auxiliary control acts on the motor of the machine through a power interface, such as a contactor or a PLC. It is an industrial control station designed for heavy duty use.

DESIGN

Mike has an innovative design, where each graphic element is linked to a specific technical function. Its dimensions and shape are the result of careful analysis of the product ergonomic aspects, aimed at achieving a graphic style that blends in with modern industrial environments, making Mike extremely handy and user friendly. Its compact dimensions and antislip grooves on the case make it easy to handle under any working conditions.

FEATURES

The innovative hanging system of Mike, with cables hidden inside the shell, enables quick, correct, ergonomic installation to prevent the danger of personal injury in everyday use. Mike has been designed to facilitate wiring and maintenance: the switches are installed in the base of the control station, together with the inlet of the cable, and are separated from the actuators, installed on the cover; this drastically reduces time and costs for installation and maintenance down time. The emergency stop mushroom pushbutton complies with ISO 13850 regulation and is equipped with positive opening NC switches.

OPTIONS

Mike is available in configurations with 4 to 15 actuators, with 1NO or 1NC switches, LEDs voltage 24/48 V AC/DC or 110/230 V AC, and potentiometers.

The range includes actuators in various colours: one or two speed buttons, selector switches and key-operated switches in various actuation configurations, pilot lights, pulsed or latched mushroom pushbuttons with rotation or key-operated release. One-speed pushbuttons and selector switches are available in illuminated version in a range of colours.

Mike comes with standard sheet of labels (symbols and lettering) to be applied to the upper cover near the actuators, according to customers' needs. Upon request Mike can be supplied with pushbuttons bearing two-colour moulded symbols, making the symbols permanent.

A specific protection is available for the actuators installed on the bottom of the control station.

MATERIALS

The 22.5 mm rubber pushbuttons ensure protection against dust penetration, to prevent them from becoming stuck when the control station is used in particularly harsh conditions.

All the materials and components used are weather resistant and guarantee protection of the unit against the penetration of water and dust.



INDUSTRIAL LIFTING



CONSTRUCTION LIFTING



INDUSTRIAL AUTOMATION



STAGE TECHNOLOGY

STANDARDS - MARKINGS - HOMOLOGATIONS

- Conformity to Community Directives:
 - 2006/95/CE: Low Voltage Directive
 - 2006/42/CE: Machinery Directive
- Conformity to Standards:
 - EN 60204-1 Safety of machinery - Electrical equipment of machines
 - EN 60947-1 Low-voltage switchgear and controlgear
 - EN 60947-5-1 Low-voltage switchgear and controlgear - Control circuit devices and switching elements - Electromechanical control circuit devices

EN 60947-5-5 Low-voltage switchgear and controlgear - Control circuit devices and switching elements - Electrical emergency stop device with mechanical latching function

- EN 60529 Degrees of protection provided by enclosures
- ISO13850 Safety of machinery - Emergency stop - Principles for design
- Regulations for the prevention of accidents BGV C 1 (only for Germany)
- CAN/CSA-C22.2 No 14-10 - Industrial Control Equipment
- UL 508 - Industrial Control Equipment

GENERAL TECHNICAL SPECIFICATIONS

- Storage ambient temperature: -40°C/+80°C
- Operational ambient temperature: -40°C/+80°C
- Protection degree: IP 66 / IP 67 / IP 69K
- Insulation category: Class II
- Cable entry: rubber cable sleeve (Ø 8+26 mm)
- Operating positions: any position
- Mechanical life:
 - 1 speed pushbutton: 10x10⁶ operations
 - 2 speed pushbutton: 10x10⁶ operations
 - illuminated pushbutton: 10x10⁶ operations
- HALT test (data available on request)
- Markings and homologations: **CE** **UL** **ER** **SIL 1**
- UL Environmental Rating: (Mike black) Type 1, 4 and 4X
(Mike yellow) Type 1, 4 and 4X indoor use only

TECHNICAL SPECIFICATIONS OF THE MICROSWITCHES

- Utilisation category: AC 15
- Rated operational current: 3 A
- Rated operational voltage: 250 Vac
- Rated thermal current: 10 A
- Rated insulation voltage: 300 Vac
- Mechanical life: 10x10⁶ operations
- Terminal referencing: according to EN 50013
- Connections: screw-type terminals
- Wires: 2x0,5mm² - 2x1,5 mm² - 1x2,5 mm²
- Tightening torque: 0.5 Nm
- Markings and homologations: **CE** **UL** **ER**

The slow action switch PRSL1800PI has 1 NO contact, double break.
The slow action switch PRSL1801PI has 1 NC, double break.
All NC contacts are of the positive opening operation type .
The switches have the following reference for internal wiring.

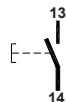

PRSL1800PI

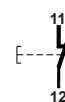

PRSL1801PI

TECHNICAL SPECIFICATIONS OF THE LEDS

- Electrical ratings PRSL1821PI: 110-240 Vac, 1.15-2.50 mA
- Electrical ratings PRSL1820PI: 24-48 Vac/dc, 1.30-2.70 mA
- Markings and homologations: **CE** **UL**



PRSL1820PI / PRSL1821PI

POSSIBLE ASSEMBLIES AND OVERALL DIMENSIONS (MM)

Standard

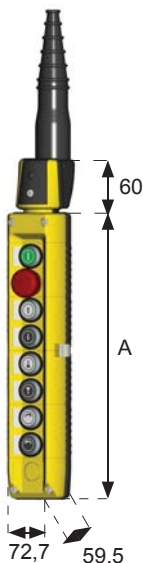

N° of buttons	Length (mm)
	A
4 / 5	201
6 / 7	261
8 / 9	321
12 / 13	441
14 / 15	501

With small lower protection



With large lower protection



The data and the products illustrated in this brochure may be modified without notice. Under no circumstances can their description have a contractual value.





TER Tecno Elettrica Ravasi srl

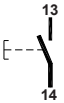
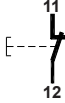

Via Garibaldi 29/31 - 23885 Calco (LC) - Italy
Registered Office - via San Vigilio 2 - 23887 Olgiate Molgora (LC) - Italy
Tel. +39 0399911011 - Fax +39 0399910445 - E-mail: info@terworld.com

www.terworld.com

TECHNICAL SPECIFICATIONS OF THE MICROSWITCHES

Code	PRSL1800PI	PRSL1801PI
Utilisation category	AC 15	
Rated operational voltage	250 V	
Rated operational current	3 A	
Rated thermal current	10 A	
Rated insulation voltage	300 Vac	
Mechanical life	10x10 ⁶ operations	
Terminal referencing	According to EN 50013	
Connections	screw-type terminals	
Wires	2x0.5mm ² - 2x1.5 mm ² - 1x2.5 mm ²	
Tightening torque	0.5 Nm	
Switch type	Double break, slow action	Double break, slow action
Contacts	1NO	1NC (All NC contacts are of the positive opening operation type )
Scheme		
Markings and homologations	CE  	

TECHNICAL SPECIFICATIONS OF THE LEDS

Code	PRSL1820PI	PRSL1821PI
Rated operational voltage	110-240 Vac	24-48 Vac/dc
Rated absorbed current	1.15-2.50 mA	1.30-2.70 mA
Scheme		
Markings and homologations	CE 	

TECHNICAL SPECIFICATIONS OF THE POTENTIOMETERS

Code	PRVV9079PE	PRVV9019PE	PRVV9039PE
Ohmic value	1 kΩ	4.7 kΩ	10 kΩ
Life time	15000 movements (minimum)		
Operational ambient temperature	-25°C / +70°C		
Mechanical angle	300°		
Actual electrical angle	267°		
Ohmic value tolerance	± 20%		

OVERALL DIMENSIONS (MM)

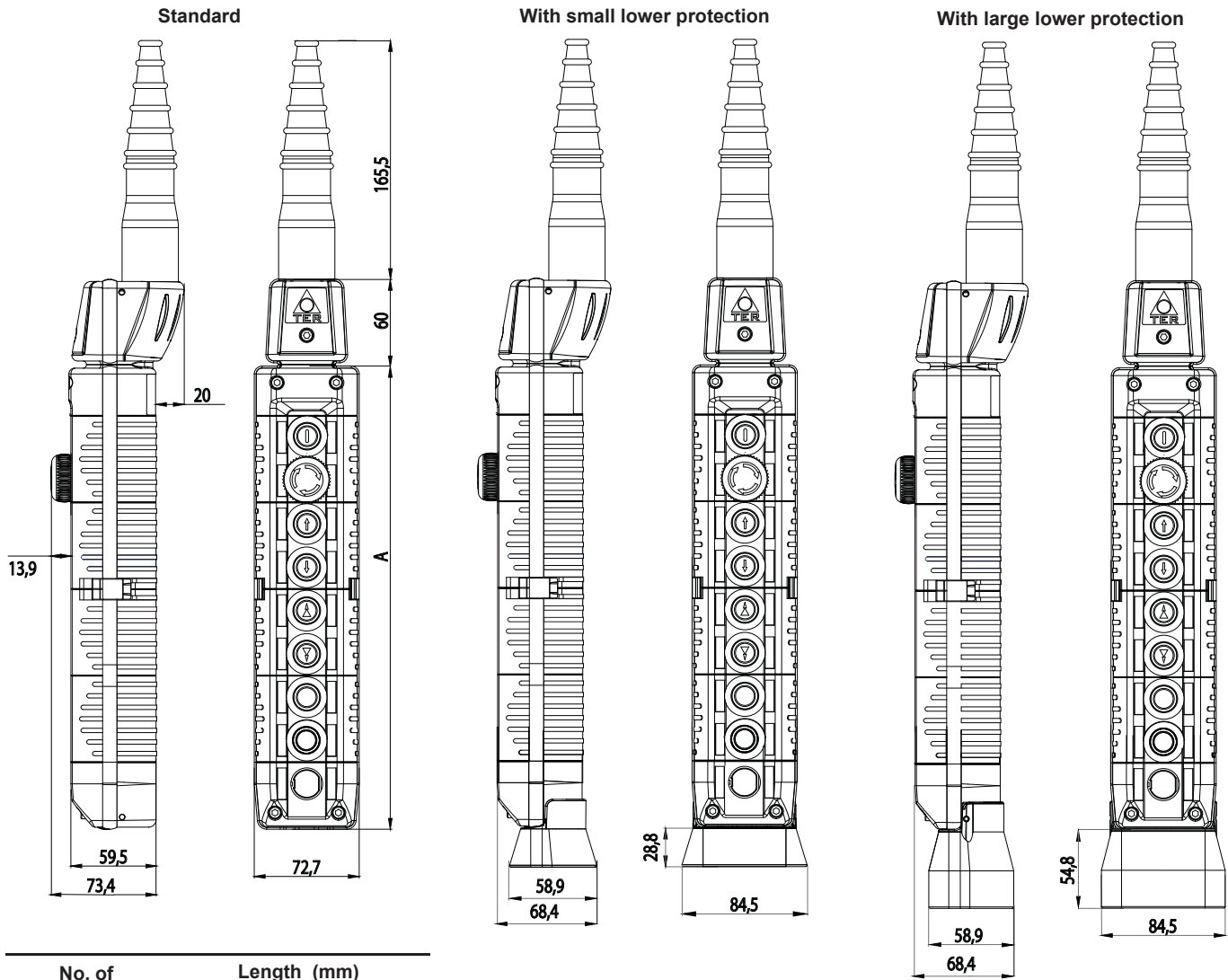

No. of buttons	Length (mm)	
	A	
4 / 5	201	
6 / 7	261	
8 / 9	321	
12 / 13	441	
14 / 15	501	

ACTUATORS

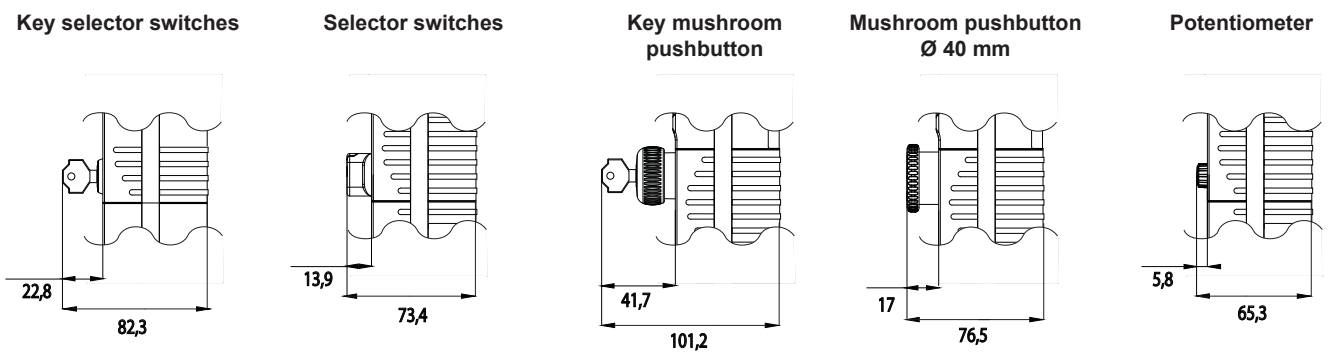

Dimensions of all mushroom pushbuttons are in released position

The data and the products illustrated in this brochure may be modified without notice. Under no circumstances can their description have a contractual value.



TER Tecno Elettrica Ravasi srl
 Via Garibaldi 29/31 - 23885 Calco (LC) - Italy
 Registered Office - via San Vigilio 2 - 23887 Olgiate Molgora (LC) - Italy
 Tel. +39 0399911011 - Fax +39 0399910445 - E-mail: info@terworld.com



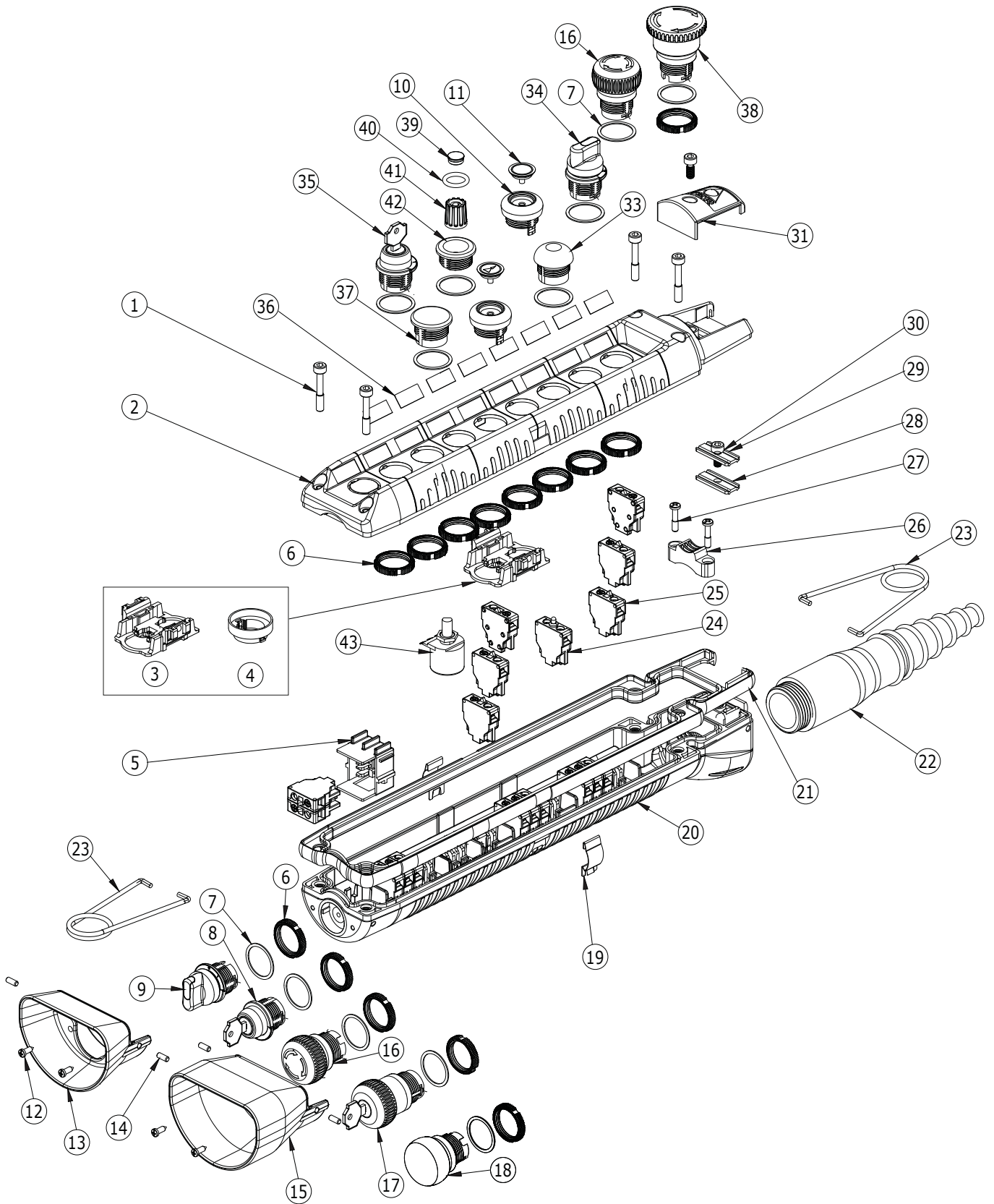

www.terworld.com

09042015-04



COMPONENTS



SWITCHES

REF	DRAWING	DESCRIPTION	SCHEME	CODE
24		LED element 24/48 V AC/DC	-	PRSL1820PI
		LED element 110/230 V AC	-	PRSL1821PI
25		1NO single switch		PRSL1800PI
		1NC single switch		PRSL1801PI

POTENTIOMETERS

REF	DRAWING	DESCRIPTION	CODE
39+40+41+42+7+6+43		Potentiometer 4.7 kΩ	PRSL1891PI
		Potentiometer 10 kΩ	PRSL1892PI
		Potentiometer 1 kΩ	PRSL1893PI

ACTUATORS

REF	DRAWING	DESCRIPTION	CODE
10+6		2 speed pushbutton	PRSL1810PI
		1 speed pushbutton	PRSL1811PI
		1 speed illuminated pushbutton	PRSL1815PI
11		Disk for button	PRTAxxxxx see Disk table
37+7+6		Blanking plug	PRSL1845PI

PILOT LIGHTS

REF	DRAWING	COLOR	CODE
33+7+6		White	PRSL1844PI
		Green	PRSL1841PI
		Blue	PRSL1846PI
		Red	PRSL1840PI
		Yellow	PRSL1842PI
		Orange	PRSL1843PI

The data and the products illustrated in this brochure may be modified without notice. Under no circumstances can their description have a contractual value.



TER Tecno Elettrica Ravasi srl





Via Garibaldi 29/31 - 23885 Calco (LC) - Italy

Registered Office - via San Vigilio 2 - 23887 Olgiate Molgora (LC) - Italy



Tel. +39 0399911011 - Fax +39 0399910445 - E-mail: info@terworld.com



www.terworld.com

MUSHROOM PUSHBUTTONS

REF	DRAWING	DESCRIPTION	HEAD COLOR	CODE
16+7+6		Latched mushroom pushbutton for emergency stop	Red	PRSL1880PI
17+7+6		Key mushroom pushbutton	Red	PRSL1890PI
18+7+6		Impulse mushroom pushbutton with black base	Red	PRSL1885ROC
			Blue	PRSL1885BLC
			Yellow	PRSL1885GIC
			Green	PRSL1885VEC
			Orange	PRSL1885ARC
			Black	PRSL1885NEC
38+7+6		Latched mushroom pushbutton for emergency stop Ø 40 mm	Red	PRSL1881PI

KEY SELECTOR SWITCHES

REF	DRAWING	POSITIONS	SPRING RETURN	MAINTAINED POSITIONS	PULL-OUT POSITION	CODE
8+7+6 and 34+7+6		0 / 1	X		0	PRSL1867PI
				X	0	PRSL1868PI
34+7+6		1 / 0 / 2	X		0	PRSL1869PI
				X	0	PRSL1870PI
			X		0	PRSL1871PI
				X	0	PRSL1872PI
			X		1	PRSL1873PI
				X	1	PRSL1874PI
		1 / 2 change over	X		1+2	PRSL1875PI
				X	1+2	PRSL1876PI

REF	DRAWING	POSITIONS	COLOR		CODE	
			TRANSPARENT	FULL		
9+7+6 and 34+7+6		0 / 1 Spring return	White		PRSL1855BI	
			Green		PRSL1855VE	
			Blue		PRSL1855BL	
			Red		PRSL1855RO	
			Yellow		PRSL1855GI	
			Orange		PRSL1855AR	
		0 / 1 Maintained	White		PRSL1856BI	
			Green		PRSL1856VE	
			Blue		PRSL1856BL	
			Red		PRSL1856RO	
			Yellow		PRSL1856GI	
			Orange		PRSL1856AR	
		0 / 1 Spring return			White	PRSL1855BIC
					Green	PRSL1855VEC
					Blue	PRSL1855BLC
					Red	PRSL1855ROC
					Yellow	PRSL1855GIC
					Orange	PRSL1855ARC
0 / 1 Maintained			White	PRSL1856BIC		
			Green	PRSL1856VEC		
			Blue	PRSL1856BLC		
			Red	PRSL1856ROC		
			Yellow	PRSL1856GIC		
			Orange	PRSL1856ARC		
34+7+6		1 / 0 / 2 Spring return	White		PRSL1857BI	
			Green		PRSL1857VE	
			Blue		PRSL1857BL	
			Red		PRSL1857RO	
			Yellow		PRSL1857GI	
			Orange		PRSL1857AR	
		1 / 0 / 2 Maintained	White		PRSL1858BI	
			Green		PRSL1858VE	
			Blue		PRSL1858BL	
			Red		PRSL1858RO	
			Yellow		PRSL1858GI	
			Orange		PRSL1858AR	
		1 / 0 / 2 Spring return			White	PRSL1857BIC
					Green	PRSL1857VEC
					Blue	PRSL1857BLC
					Red	PRSL1857ROC
					Yellow	PRSL1857GIC
					Orange	PRSL1857ARC
1 / 0 / 2 Maintained			White	PRSL1858BIC		
			Green	PRSL1858VEC		
			Blue	PRSL1858BLC		
			Red	PRSL1858ROC		
			Yellow	PRSL1858GIC		
			Orange	PRSL1858ARC		

The data and the products illustrated in this brochure may be modified without notice. Under no circumstances can their description have a contractual value.



TER Tecno Elettrica Ravasi srl

Via Garibaldi 29/31 - 23885 Calco (LC) - Italy

Registered Office - via San Vigilio 2 - 23887 Olgiate Molgora (LC) - Italy

Tel. +39 0399911011 - Fax +39 0399910445 - E-mail: info@terworld.com

www.terworld.com



SELECTOR SWITCHES

REF	DRAWING	POSITIONS	COLOR		CODE
			TRANSPARENT	FULL	
34+7+6		1 / 1+2 / 2 Spring return	White		PRSL1863BI
			Green		PRSL1863VE
			Blue		PRSL1863BL
			Red		PRSL1863RO
			Yellow		PRSL1863GI
			Orange		PRSL1863AR
		1 / 1+2 / 2 Maintained	White		PRSL1864BI
			Green		PRSL1864VE
			Blue		PRSL1864BL
			Red		PRSL1864RO
			Yellow		PRSL1864GI
			Orange		PRSL1864AR
		1 / 1+2 / 2 Spring return		White	PRSL1863BIC
				Green	PRSL1863VEC
				Blue	PRSL1863BLC
				Red	PRSL1863ROC
				Yellow	PRSL1863GIC
				Orange	PRSL1863ARC
		1 / 1+2 / 2 Maintained		White	PRSL1864BIC
				Green	PRSL1864VEC
				Blue	PRSL1864BLC
				Red	PRSL1864ROC
				Yellow	PRSL1864GIC
				Orange	PRSL1864ARC
0 / 1 / 1+2 Spring return	White		PRSL1859BI		
	Green		PRSL1859VE		
	Blue		PRSL1859BL		
	Red		PRSL1859RO		
	Yellow		PRSL1859GI		
	Orange		PRSL1859AR		
0 / 1 / 1+2 Maintained	White		PRSL1860BI		
	Green		PRSL1860VE		
	Blue		PRSL1860BL		
	Red		PRSL1860RO		
	Yellow		PRSL1860GI		
	Orange		PRSL1860AR		
0 / 1 / 1+2 Spring return		White	PRSL1859BIC		
		Green	PRSL1859VEC		
		Blue	PRSL1859BLC		
		Red	PRSL1859ROC		
		Yellow	PRSL1859GIC		
		Orange	PRSL1859ARC		
0 / 1 / 1+2 Maintained		White	PRSL1860BIC		
		Green	PRSL1860VEC		
		Blue	PRSL1860BLC		
		Red	PRSL1860ROC		
		Yellow	PRSL1860GIC		
		Orange	PRSL1860ARC		

SELECTOR SWITCHES

REF	DRAWING	POSITIONS	COLOR		CODE	
			TRANSPARENT	FULL		
34+7+6		1 / 2 Spring return	White		PRSL1861BI	
			Green		PRSL1861VE	
			Blue		PRSL1861BL	
			Red		PRSL1861RO	
			Yellow		PRSL1861GI	
			Orange		PRSL1861AR	
		1 / 2 Maintained	White		PRSL1862BI	
			Green		PRSL1862VE	
			Blue		PRSL1862BL	
			Red		PRSL1862RO	
			Yellow		PRSL1862GI	
			Orange		PRSL1862AR	
		1 / 2 Spring return		White		PRSL1861BIC
				Green		PRSL1861VEC
				Blue		PRSL1861BLC
				Red		PRSL1861ROC
				Yellow		PRSL1861GIC
				Orange		PRSL1861ARC
		1 / 2 Maintained		White		PRSL1862BIC
				Green		PRSL1862VEC
				Blue		PRSL1862BLC
				Red		PRSL1862ROC
				Yellow		PRSL1862GIC
				Orange		PRSL1862ARC

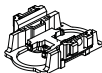
ACCESSORIES

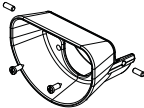
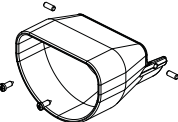
REF	DRAWING	DESCRIPTION	CODE
3		Mechanical interlock	PRSL1850PI
4		Button-switch spacer	PRSL8512PI
5		1-2-3 switch holder	PRSL8750PI
13+12+14		Small protection	PRSL1830PI
15+12+14		Large protection	PRSL1831PI

The data and the products illustrated in this brochure may be modified without notice. Under no circumstances can their description have a contractual value.







TER Tecno Elettrica Ravasi srl

Via Garibaldi 29/31 - 23885 Calco (LC) - Italy
 Registered Office - via San Vigilio 2 - 23887 Olgiate Molgora (LC) - Italy
 Tel. +39 0399911011 - Fax +39 0399910445 - E-mail: info@terworld.com



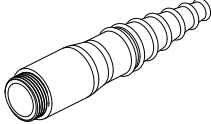
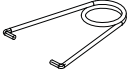



























www.terworld.com

09042015-10

ACCESSORIES

REF	DRAWING	DESCRIPTION	CODE
19		Closing clip	PRTR1035PE
22		Cable sleeve	PRSL0145PE
23		Hook	PRGA0012PE
28+29+30		Complete wire clamp	PRSL1896PI
31+32		Cable cover with logo TER	PRSL1832PI
		Neutral cable cover	PRSL1836PI
		Label sheet - symbols	PRET0215PE
		Label sheet - German	PRET0220DE
		Label sheet - English	PRET0220EN
		Label sheet - Spanish	PRET0220ES
36		Label sheet - French	PRET0220FR
		Label sheet - Italian	PRET0220IT

FULL COLOR DISKS

GREEN  PRTA001MPI	RED  PRTA002MPI	YELLOW  PRTA003MPI	GREEN  PRTA004MPI	 PRTA005MPI	 PRTA006MPI	 PRTA007MPI	 PRTA008MPI	 PRTA011MPI	 PRTA012MPI
 PRTA015MPI	 PRTA016MPI	 PRTA018MPI	 PRTA019MPI	 PRTA022MPI	 PRTA023MPI	 PRTA026MPI	 PRTA027MPI	 PRTA032MPI	GREEN  PRTA033MPI
RED  PRTA034MPI	BLUE  PRTA035MPI	YELLOW  PRTA036MPI	YELLOW  PRTA097MPI	WHITE  PRTA098MPI	BLACK  PRTA099MPI	GREEN  PRTA096MPI	RED  PRTA095MPI	BLUE  PRTA094MPI	ORANGE  PRTA093MPI



TRANSPARENT DISKS

YELLOW  PRTA097MPIT	WHITE  PRTA098MPIT	GREEN  PRTA096MPIT	RED  PRTA095MPIT	BLUE  PRTA094MPIT	ORANGE  PRTA093MPIT
--	---	---	--	--	--

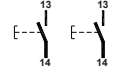

STANDARD CONTROL STATIONS

Standard control stations are supplied with symbol label sheets.

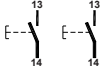

4 ACTUATORS

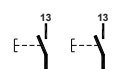
	RESET ALARM BUTTON	EMERGENCY STOP MUSHROOM PUSHBUTTON	BLACK BUTTONS MECHANICALLY INTERLOCKED BETWEEN PAIRS		UPPER COVER COLOR	CODE
	N.2 PRSL1800PI 1NO+1NO	N.1 PRSL1801PI 1NC	N.1 PRSL1800PI 1NO	N.2 PRSL1800PI 1NO+1NO		
						
	1	1	2		Yellow	F70AY1202000001
	1	1	2		Black	F70AB1202000001
	1	1		2	Yellow	F70AY12000200001
	1	1		2	Black	F70AB12000200001

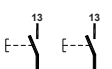

6 ACTUATORS

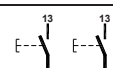
	RESET ALARM BUTTON	EMERGENCY STOP MUSHROOM PUSHBUTTON	BLACK BUTTONS MECHANICALLY INTERLOCKED BETWEEN PAIRS		UPPER COVER COLOR	CODE
	N.2 PRSL1800PI 1NO+1NO	N.1 PRSL1801PI 1NC	N.1 PRSL1800PI 1NO	N.2 PRSL1800PI 1NO+1NO		
						
	1	1	4		Yellow	F70EY12040000002
	1	1	4		Black	F70EB12040000001
	1	1		4	Yellow	F70EY12000400002
	1	1		4	Black	F70EB12000400001

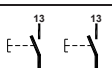

8 ACTUATORS

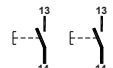
	RESET ALARM BUTTON	EMERGENCY STOP MUSHROOM PUSHBUTTON	BLACK BUTTONS MECHANICALLY INTERLOCKED BETWEEN PAIRS		UPPER COVER COLOR	CODE
	N.2 PRSL1800PI 1NO+1NO	N.1 PRSL1801PI 1NC	N.1 PRSL1800PI 1NO	N.2 PRSL1800PI 1NO+1NO		
						
	1	1	6		Yellow	F70BY12060000001
	1	1	6		Black	F70BB12060000001
	1	1		6	Yellow	F70BY12000600001
	1	1		6	Black	F70BB12000600001

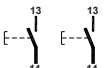
12 ACTUATORS

	RESET ALARM BUTTON	EMERGENCY STOP MUSHROOM PUSHBUTTON	BLACK BUTTONS MECHANICALLY INTERLOCKED BETWEEN PAIRS		UPPER COVER COLOR	CODE
	N.2 PRSL1800PI 1NO+1NO	N.1 PRSL1801PI 1NC	N.1 PRSL1800PI 1NO	N.2 PRSL1800PI 1NO+1NO		
						
	1	1	10		Yellow	F70CY12100000001
	1	1	10		Black	F70CB12100000001
	1	1		10	Yellow	F70CY12001000001
	1	1		10	Black	F70CB12001000001

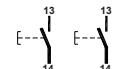
14 ACTUATORS

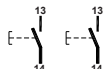
	RESET ALARM BUTTON	EMERGENCY STOP MUSHROOM PUSHBUTTON	BLACK BUTTONS MECHANICALLY INTERLOCKED BETWEEN PAIRS		UPPER COVER COLOR	CODE
	N.2 PRSL1800PI 1NO+1NO	N.1 PRSL1801PI 1NC	N.1 PRSL1800PI 1NO	N.2 PRSL1800PI 1NO+1NO		
						
	1	1	12		Yellow	F70DY12120000001
	1	1	12		Black	F70DB12120000001
	1	1		12	Yellow	F70DY12001200001
	1	1		12	Black	F70DB12001200001

The data and the products illustrated in this brochure may be modified without notice. Under no circumstances can their description have a contractual value.



TER Tecno Elettrica Ravasi srl

Via Garibaldi 29/31 - 23885 Calco (LC) - Italy

Registered Office - via San Vigilio 2 - 23887 Olgiate Molgora (LC) - Italy

Tel. +39 0399911011 - Fax +39 0399910445 - E-mail: info@terworld.com

www.terworld.com

MIKE - REQUEST FORM FOR NON STANDARD PENDANT STATIONS

Instructions

(See next page for list of components and legends)

Fill in the chart to the left according to the number of control elements required. Control stations are available with 5, 7, 9, 13 or 15 control elements. It is not possible to assemble the last button on the cover if a control element is assembled on the bottom of the control station, and vice versa. If necessary, you can possibly use a longer control station enclosure.

- 1 Control elements:** enter the number corresponding to the control element required (1 to 39) according to the legend. Eg.
- 2 Button disks and colors:** for pushbuttons (1 to 3) enter the number corresponding to the disk required (50 to 85) according to the legend. Both full color disks and transparent disks (for illuminated buttons) are available. Eg.
- 3 Color of selectors, mushrooms, pilot lights:** for toggle selector switches (15 to 24), impulse mushroom pushbuttons (7) and pilot lights (11) enter the code corresponding to the color required according to the legend. Eg.
- 4** If you choose **disks with arrows** (legend 54 to 72), enter the direction of the arrow in the circle. Eg. 
- 5 Switches, LEDs and potentiometers:** enter the number corresponding to the switch, LED or potentiometer required (90 to 93) according to the legend. It is possible to enter up to 3 switches per position. Es.
2 speed pushbuttons can activate two switches on the first speed and one switch on the second speed.
Selector switches can activate only two switches and possibly a LED.
ATTENTION: LEDs can be placed only in the central position and they are used for illuminated buttons and selector switches (See Control Elements legend for switch activation)
- 6 Hook:** tick the box at the top or at the bottom if the hook is required. Eg. ~~Hook~~
- 7 Cable sleeve:** tick the box if the cable sleeve is required. Eg. ~~Sleeve~~
- 8 Mechanical interlock:** tick the boxes where mechanical interlock between two control elements is required. Eg. ~~X~~
- 9 Protection:** when a control element is mounted on the bottom of the control station, it is possible to use a protection; in this case tick the box corresponding to the protection required. Eg. ~~Small~~
- 10 Cover:** tick the box corresponding to the cover color required (the base of the enclosure is always black).
- 11 SIL 1 certified:** tick the box if you require SIL 1 certified units for safety functions.
- 12 Adhesive labels:** stickers with letterings or symbols may be placed on the left and on the right of any control element. If label sheets are required, tick the corresponding box.

Control element on the bottom of the control station*

Control element **1**

Color **3**

Switches **5**

Protection **9**

*ATTENTION: only mushroom pushbuttons with ref. 4, 5, 6 with one or two switches, or **non illuminated** selector switches ref. 15, 16, 30, 31 with only one switch can be assembled on the bottom of the control station. LEDs can not be mounted in this position.

















Cover **10** Yellow Black

SIL 1 certified **11**

Adhesive labels **12**

Symbols English French

Italian German Spanish

1	2	3	6	7	5
Control elements	Button disks and colors	Color of selectors, mushrooms, pilot lights	Hook	Sleeve	Switches and LEDs
<input type="checkbox"/>	<input type="checkbox"/>	<input type="checkbox"/>			<input type="checkbox"/>
<input type="checkbox"/>	<input type="checkbox"/>	<input type="checkbox"/>		4 	<input type="checkbox"/>
<input type="checkbox"/>	<input type="checkbox"/>	<input type="checkbox"/>		8 <input type="text" value="MI"/>	<input type="checkbox"/>
<input type="checkbox"/>	<input type="checkbox"/>	<input type="checkbox"/>			<input type="checkbox"/>
<input type="checkbox"/>	<input type="checkbox"/>	<input type="checkbox"/>		<input type="text" value="MI"/>	<input type="checkbox"/>
<input type="checkbox"/>	<input type="checkbox"/>	<input type="checkbox"/>			<input type="checkbox"/>
<input type="checkbox"/>	<input type="checkbox"/>	<input type="checkbox"/>		<input type="text" value="MI"/>	<input type="checkbox"/>
<input type="checkbox"/>	<input type="checkbox"/>	<input type="checkbox"/>			<input type="checkbox"/>
<input type="checkbox"/>	<input type="checkbox"/>	<input type="checkbox"/>		<input type="text" value="MI"/>	<input type="checkbox"/>
<input type="checkbox"/>	<input type="checkbox"/>	<input type="checkbox"/>			<input type="checkbox"/>
<input type="checkbox"/>	<input type="checkbox"/>	<input type="checkbox"/>		<input type="text" value="MI"/>	<input type="checkbox"/>
<input type="checkbox"/>	<input type="checkbox"/>	<input type="checkbox"/>			<input type="checkbox"/>
<input type="checkbox"/>	<input type="checkbox"/>	<input type="checkbox"/>		<input type="text" value="MI"/>	<input type="checkbox"/>
<input type="checkbox"/>	<input type="checkbox"/>	<input type="checkbox"/>			<input type="checkbox"/>
<input type="checkbox"/>	<input type="checkbox"/>	<input type="checkbox"/>		<input type="text" value="MI"/>	<input type="checkbox"/>
<input type="checkbox"/>	<input type="checkbox"/>	<input type="checkbox"/>			<input type="checkbox"/>
<input type="checkbox"/>	<input type="checkbox"/>	<input type="checkbox"/>		<input type="text" value="MI"/>	<input type="checkbox"/>
<input type="checkbox"/>	<input type="checkbox"/>	<input type="checkbox"/>			<input type="checkbox"/>
<input type="checkbox"/>	<input type="checkbox"/>	<input type="checkbox"/>		<input type="text" value="MI"/>	<input type="checkbox"/>
<input type="checkbox"/>	<input type="checkbox"/>	<input type="checkbox"/>			<input type="checkbox"/>
<input type="checkbox"/>	<input type="checkbox"/>	<input type="checkbox"/>		<input type="text" value="MI"/>	<input type="checkbox"/>
<input type="checkbox"/>	<input type="checkbox"/>	<input type="checkbox"/>			<input type="checkbox"/>
<input type="checkbox"/>	<input type="checkbox"/>	<input type="checkbox"/>		<input type="text" value="MI"/>	<input type="checkbox"/>
<input type="checkbox"/>	<input type="checkbox"/>	<input type="checkbox"/>			<input type="checkbox"/>
<input type="checkbox"/>	<input type="checkbox"/>	<input type="checkbox"/>		<input type="text" value="MI"/>	<input type="checkbox"/>
<input type="checkbox"/>	<input type="checkbox"/>	<input type="checkbox"/>			<input type="checkbox"/>
<input type="checkbox"/>	<input type="checkbox"/>	<input type="checkbox"/>		<input type="text" value="MI"/>	<input type="checkbox"/>
<input type="checkbox"/>	<input type="checkbox"/>	<input type="checkbox"/>			<input type="checkbox"/>
<input type="checkbox"/>	<input type="checkbox"/>	<input type="checkbox"/>		<input type="text" value="MI"/>	<input type="checkbox"/>
<input type="checkbox"/>	<input type="checkbox"/>	<input type="checkbox"/>			<input type="checkbox"/>
<input type="checkbox"/>	<input type="checkbox"/>	<input type="checkbox"/>		<input type="text" value="MI"/>	<input type="checkbox"/>
<input type="checkbox"/>	<input type="checkbox"/>	<input type="checkbox"/>			<input type="checkbox"/>
<input type="checkbox"/>	<input type="checkbox"/>	<input type="checkbox"/>	6 <input type="checkbox"/> Hook		<input type="checkbox"/>

1 MIKE - Legend - Control elements

* SWITCH ACTIVATION

It is possible to mount up to 3 switches for each control element. The chart on the right of each pushbutton or selector switch specifies which position activates the switch on the top, in the middle or on the bottom. If the selector switches are mounted with the lever facing downwards, then the activation of the switches is reversed. Eg.: 2 speed pushbutton: the first speed activates the switches on the top and in the middle, while the second speed activates the switch on the bottom.

Pushbuttons

It is possible to mount up to three switches for each button. LEDs can be mounted only in the middle.

		SWITCH ACTIVATION*	
1	1 speed pushbutton	<input type="checkbox"/> speed 1	<input type="checkbox"/> speed 1
2	2 speed pushbutton	<input type="checkbox"/> speed 1	<input type="checkbox"/> speed 2
3	1 speed illuminated pushbutton	<input type="checkbox"/> speed 1 LED	<input type="checkbox"/> speed 1

Mushroom pushbuttons

All mushroom pushbuttons activate all the switches at the same time.

- 4 Latched mushroom pushbutton for emergency stop
- 5 Latched mushroom pushbutton for emergency stop Ø 40 mm
- 6 Key mushroom pushbutton
- 7 Impulse mushroom pushbutton with black base

11 Pilot light

12 Blanking plug

Toggle selector switches

It is possible to mount only two switches for each selector. In the middle it is possible to mount only the LED for illuminated selector switches.

		SWITCH ACTIVATION*	
15	0 / 1 spring return	<input type="checkbox"/> pos 1	<input type="checkbox"/> pos 1
16	0 / 1 maintained positions	<input type="checkbox"/> pos 1	<input type="checkbox"/> pos 1
17	1 / 0 / 2 spring return	<input type="checkbox"/> pos 1	<input type="checkbox"/> pos 2
18	1 / 0 / 2 maintained positions	<input type="checkbox"/> pos 1	<input type="checkbox"/> pos 2
19	1 / 1+2 / 2 spring return	<input type="checkbox"/> pos 1 and 1+2	<input type="checkbox"/> pos 2 and 1+2
20	1 / 1+2 / 2 maintained positions	<input type="checkbox"/> pos 1 and 1+2	<input type="checkbox"/> pos 2 and 1+2
21	0 / 1 / 1+2 spring return	<input type="checkbox"/> pos 1+2	<input type="checkbox"/> pos 1 and 1+2
22	0 / 1 / 1+2 maintained positions	<input type="checkbox"/> pos 1+2	<input type="checkbox"/> pos 1 and 1+2
23	1 / 2 spring return	<input type="checkbox"/> pos 1	<input type="checkbox"/> pos 2
24	1 / 2 maintained positions	<input type="checkbox"/> pos 1	<input type="checkbox"/> pos 2

Key selector switches

It is possible to mount only two switches for each selector, and no switch/LED in the central position.

		SWITCH ACTIVATION*	
30	0 / 1 spring return key out in position 0	<input type="checkbox"/> pos 1	<input type="checkbox"/> pos 1
31	0 / 1 maintained positions key out in position 0	<input type="checkbox"/> pos 1	<input type="checkbox"/> pos 1
32	1 / 0 / 2 spring return key out in position 0	<input type="checkbox"/> pos 1	<input type="checkbox"/> pos 2
33	1 / 0 / 2 maintained positions key out in position 0	<input type="checkbox"/> pos 1	<input type="checkbox"/> pos 2
34	0 / 1 / 1+2 spring return key out in position 0	<input type="checkbox"/> pos 1+2	<input type="checkbox"/> pos 1 and 1+2
35	0 / 1 / 1+2 maintained positions key out in position 0	<input type="checkbox"/> pos 1+2	<input type="checkbox"/> pos 1 and 1+2
36	1 / 2 change-over spring return key out in position 1	<input type="checkbox"/> pos 1	<input type="checkbox"/> pos 2
37	1 / 2 change-over maintained positions key out in position 1	<input type="checkbox"/> pos 1	<input type="checkbox"/> pos 2
38	1 / 1+2 / 2 spring return key out in position 1+2	<input type="checkbox"/> pos 1 and 1+2	<input type="checkbox"/> pos 2 and 1+2
39	1 / 1+2 / 2 maintained positions key out in position 1+2	<input type="checkbox"/> pos 1 and 1+2	<input type="checkbox"/> pos 2 and 1+2

2 Legend - Button disks and colors

Full color and symbol disks for pushbuttons (ref. 1 and 2)

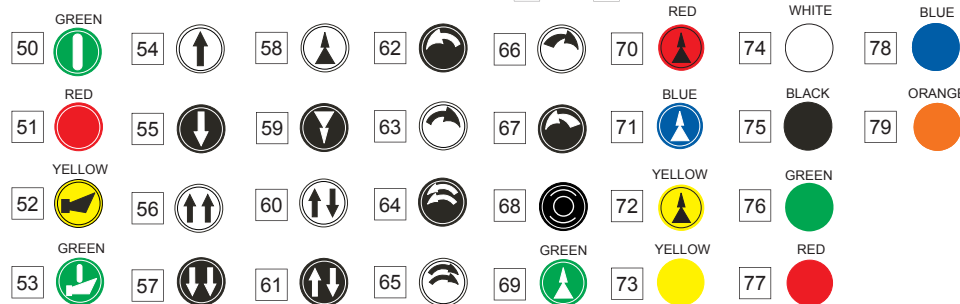

Transparent disks for illuminated buttons (ref. 3)

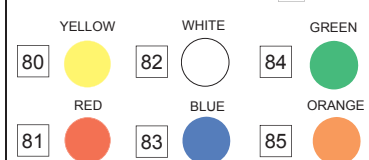

3 Legend - Color of selectors, mushrooms, pilot lights

Non-illuminated toggle selector switches (ref. 15 to 24)

RP	Red	BP	Blue	AP	Orange
GP	Yellow	VP	Green	WP	White

Illuminated toggle selector switches (ref. 15 to 24)

RI	Red	BI	Blue	AI	Orange
GI	Yellow	VI	Green	WI	White

Impulse mushroom pushbutton with black base (ref. 7)

R	Red	B	Blue	A	Orange
G	Yellow	V	Green	N	Black

Pilot lights (ref. 11)

R	Red	B	Blue	A	Orange
G	Yellow	V	Green	W	White

5 Legend - Switches, LEDs, potentiometers

- 90 PRSL1800PI - 1NO switch
- 91 PRSL1801PI - 1NC switch
- 92 PRSL1820PI LED 24/48 V AC/DC
- 93 PRSL1821PI LED 110/230 V AC
- 94 PRSL1891PI potentiometer 4.7 kΩ
- 95 PRSL1892PI potentiometer 10 kΩ
- 96 PRSL1893PI potentiometer 1 kΩ

The data and the products illustrated in this brochure may be modified without notice. Under no circumstances can their description have a contractual value.



TER Tecno Elettrica Ravasi srl

Via Garibaldi 29/31 - 23885 Calco (LC) - Italy
 Registered Office - via San Vigilio 2 - 23887 Olgiate Molgora (LC) - Italy
 Tel. +39 0399911011 - Fax +39 0399910445 - E-mail: info@terworld.com

www.terworld.com

USE AND MAINTENANCE INSTRUCTIONS

Mike Pendant Control Station is an electromechanical device for low voltage control circuits (EN 60947-1, EN 60947-5-1) to be used as electrical equipment on machines (EN 60204-1) in compliance with the fundamental requirements of the Low Voltage Directive 2006/95/CE and of the Machine Directive 2006/42/CE.

The pendant station is designed for industrial use and also for use under particularly severe climatic conditions (operational temperature from -40°C to +80°C, suitable for use in tropical environment).

The equipment is not suitable for use in environments with potentially explosive atmosphere, corrosive agents or a high percentage of sodium chloride (saline fog). Oils, acids or solvents may damage the equipment; avoid using them for cleaning.

Do not connect more than one phase to each switch. Do not oil or grease the control elements or the switches.

The installation of the pendant station shall be carried out by expert and trained personnel. Wiring shall be properly done according to the current instructions.

Prior to the installation and the maintenance of the pendant station, the main power of the machinery shall be turned off.

Steps for the proper installation of the pendant station

1. Open the pendant station
2. Screw the variable section rubber cable sleeve (6) into the enclosure (14)
3. Cut the cable sleeve (6) and insert the multi-pole cable tight enough to guarantee protection against water and/or dust
4. Strip the cable to a length suitable for wiring the switches/LED (10)
5. Tape the stripped part of the cable
6. Fix the multi-pole cable inside the pendant station using the variable section cable clamp (9) (supplied together with the fixing screws (8), inside the "Accessories bag")
7. Tighten the cable tie (15) (inside the "Accessories bag") under the chosen measure ring on the cable sleeve (6)
8. Connect all the switches/LED (10) according to the wiring layout printed on the switches /LED and overleaf (tighten the wires into the terminals with a torque equal to 0.5 Nm; (UL (c)UL: use 60°C or 75°C copper (CU) conductors and stiff or flexible wire 14-16 AWG); insertability of wires into the terminals 2x0.5mm² 2x1.5 mm² 1x2.5 mm²)
9. Close the pendant station checking the proper positioning of the tightening gasket (13), making sure the gasket fits well into the cover and the enclosure seats. ATTENTION: make sure no cable is in between the switches/LED (10) and the actuators (16) mounted on the upper cover (11). Fix the closing clips (12), if provided and depending on the assembly. Tighten the fixing screws (3) on the cover with a torque of 250 cNm.
10. Screw the clamping plates (4, 5) into their seat on the enclosure (14)
11. Fasten the holding wires, used to support the multi-pole cable, to the clamping plates (4, 5). ATTENTION: make sure the holding wires are as close as possible to the screw. After positioning the holding wires, tighten the screw
12. Position the wire cover (2) and tighten the screw (1) with a torque of 250 cNm. Insert the hook (7) into its seats on the enclosure (14)
13. In order to open the control station, loosen the screws on the cover (3), remove the clips (12), if provided, loosen the screw (1) and remove the wire cover (2), and loosen the clamping plate (4)

CAUTION: Do not operate on the actuators when the control station is not perfectly closed (with screws tightened and clips fitted as described in point 9) as this may cause the release of the mechanical interlock. If this happens, re-position the mechanical interlock before closing the control station.

Periodic maintenance steps

- Check the proper tightening of the screws (3) of the enclosure (11, 14)
- Check the proper tightening of the switch/LED (10) terminal screws
- Check the wiring conditions (in particular where wires clamp into the switches)
- Check the conditions of the tightening gasket (13), of the rubber of the actuators (16) and of the cable sleeve (6)
- Check that the plastic enclosure (11, 14) of the pendant station is not broken
- Check the proper assembling of the clips (12), if provided

In case any component of the pendant station is modified, the validity of the markings and the guarantee on the equipment are annulled. Should any component need replacement, use original spare parts only.

TER declines all responsibility for damages caused by the improper use or installation of the equipment.

Specifications UL

Technical Specifications UL

Code Mike certified UL = F80XXXXXXXXXXXXX
Category = NKCR / NKCR7
Contact Blocks Rating = A600, Q600
LED PRSL1821PI Rating = 110 – 240VAC, 1.15 – 2.50 mA
LED PRSL1820PI Rating = 24 – 48 VDC/AC, 1.30 – 2.70 mA
Environmental Rating (Mike black) = Type 1, 4 and 4X
Environmental Rating (Mike yellow) = Type 1, 4 and 4X indoor use only
Cord diameter range = from 0.31 in (8mm) to 0.91 in (23mm)
Cord type = flexible, type minimum SW or SJW (ZJCZ/7)
Wire size range = 14-16 AWG stranded or solid
Conductors = Copper (CU) 60/75°C
Terminal tightening torque = 4.50 lb.in (0.5Nm)
Marking = 

Protection PRSL1830PI, PRSL1831PI

When the pilot light / selector switch / key selector switch / impulse mushroom pushbutton / mushroom push-button / emergency mushroom push-button / emergency key mushroom push-button / actuator is mounted on the bottom of the enclosed pendant control stations, the large protection PRSL1831PI or small protection PRSL1830PI shall be used.

Emergency Stop Button

Category = NISD3
Code = PRSL1880P1, PRSL1881PI
Contact Blocks = PRSL1801PI (A600, Q600)
Optional Contact Blocks = PRSL1800PI (A600, Q600)

Code = PRSL1890PI
Contact Blocks = PRSL1801PI (A600, Q600)

These unlisted components "emergency stop buttons" are intended for use within
TECNO ELETTRICA RAVASI S R L Listed (NKCR) Mike and Victor pushbutton stations.

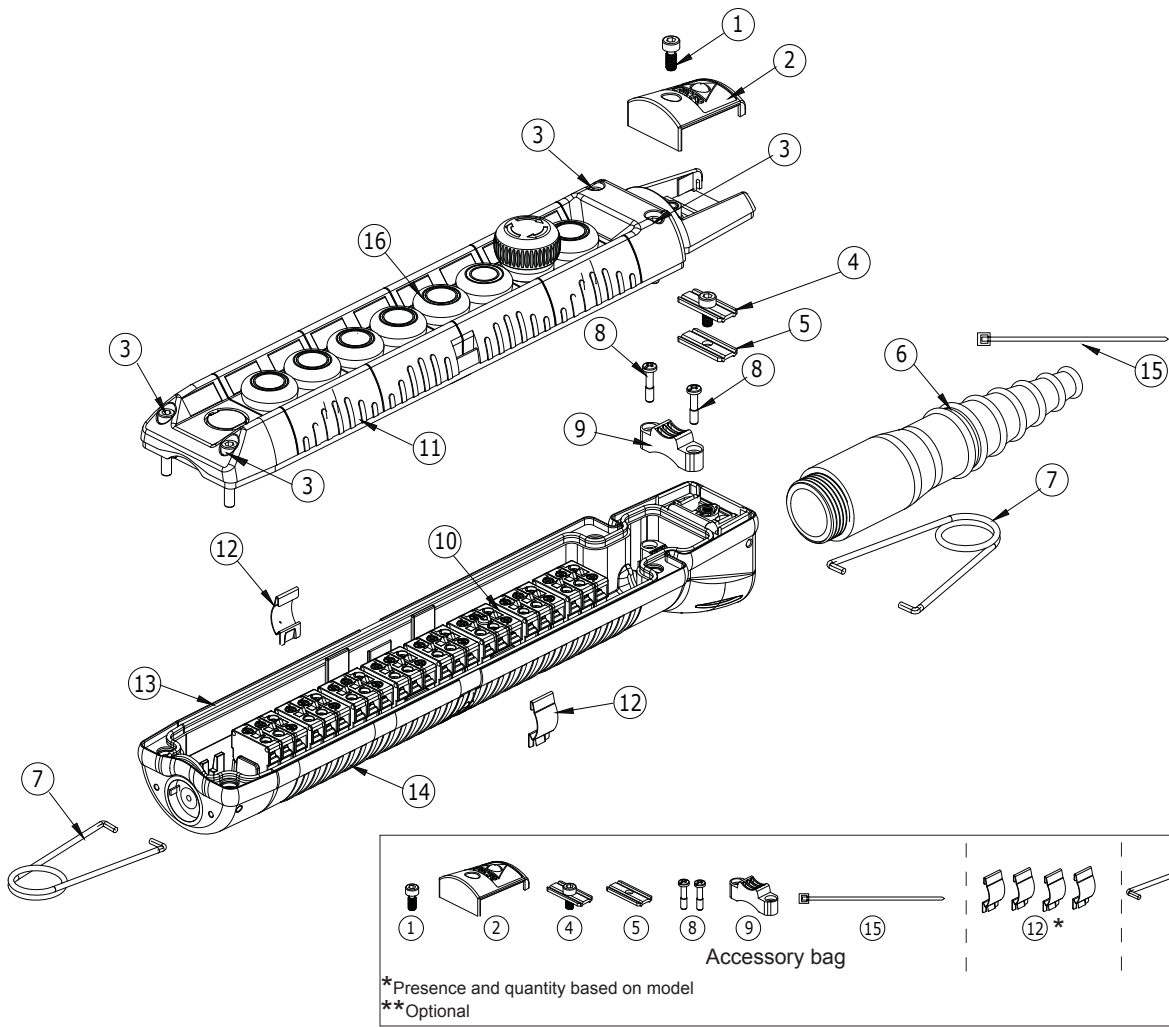

SWITCH ACTIVATION

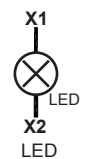
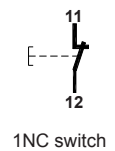
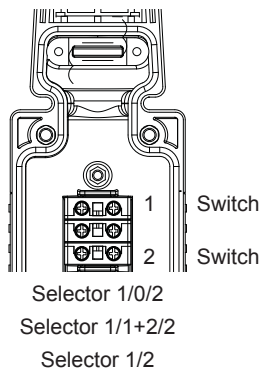
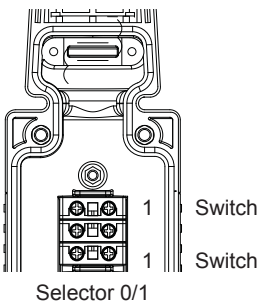
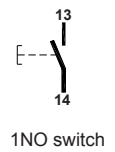
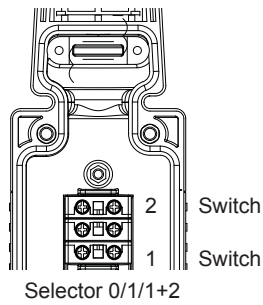
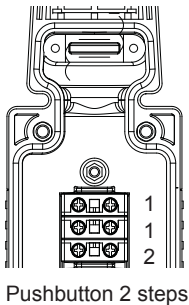

The data and the products illustrated in this brochure may be modified without notice. Under no circumstances can their description have a contractual value.



TER Tecno Elettrica Ravasi srl

Via Garibaldi 29/31 - 23885 Calco (LC) - Italy

Registered Office - via San Vigilio 2 - 23887 Olgiate Molgora (LC) - Italy

Tel. +39 0399911011 - Fax +39 0399910445 - E-mail: info@terworld.com

www.terworld.com